

N3ZI Kits

General Coverage Receiver, Assembly & Operations Manual

(For Jun 2010 PCB)

Version 2.3, JULY 2010



Thank you for purchasing my general coverage receiver kit. You can use the photo above as a guide to assembly. The silk screen on the PCB can also be used as an assembly guide.

You should also realize the the color and appearance of the parts in your kit may be slightly different from the ones in the photo above, especially with capacitors. Also you can see that the SA612 mixer IC's in the above photo (the 8 pin dips) have sockets. We do not supply sockets in the kit, and recommend that you solder the chips directly in the board.

Shown below is the parts list, but your shipment will include a packing list which will be more up to date than this one. If you purchased a different version of this kit, such as the single band or single frequency version, refer to the later section of this manual.

Parts list (BOM) June 2010 PCB version

Qty	Type	Value	Color Appearance / Marking	Designator on PCB
1	PCB	PCB	Jun 2010	Jun 2010
4	Capacitor	0.10uF	Yellow, 104	C19, C20, C21,C22
5	Capacitor	0.01uF	Yellow, 103	C12, C13,C14, C15, C16
3	Capacitor	180pF	Yellow, 181	C7, C9, C11
2	Capacitor	120pF	Orange/Yellow, 121	C8, C10
3	Capacitor	220pF	Yellow, 221	C4, C5, C6
2	Capacitor	470pF	Yellow, 471	C1, C3
1	Capacitor	680pF	Yellow, 681	C2
2	Capacitor	27pF	Orange 27	C17, C18
1	Trimmer Cap	40pF	Yellow	C23
3	Capacitor, Elec	47uF/ 25v	Black Radial	C24,C25,C26
1	Crystal	11.046MHz	11.04-S	X5
4	Crystal	11.059MHz	11.0592 MP-1	X1, X2, X3, X4
2	I.C, Mixer	SA612	SA612	U1, U2
2	Resistor	220 ohms	Red, Red, Brown	R2, R7
2	Resistor	330 ohms	Orange, Orange Brown	R1, R9
1	Resistor	10 ohms	Brown, Black, Black	R8
2	Resistor	1K ohms	Brown, Black, Red	R3, R6
3	Resistor	4.7K ohms	Yellow, Purple, Red	R4, R5, R10
1	FT-50-43 Core	3T to 23T	Black	T1
2	Transistor	C1674	C1674	Q1, Q2
2	Transistor	2N4124	2N4124	Q3, Q4
2	Power Diode	1N4001	Black Epoxy	D1, D2
1	Zener Diode	7.5V	Glass	D3
2	Inductor	1uH	Brown, Black, Gold	L1, L2
2	Inductor	0.22uH	Red, Red, Silver	L3, L4
1	Relay	DPDT	White	RY1
1	RCA Jack	RCA Jack	White	J1
1	Power Jack	2.1 mm	Black	J4
1	Audio Jack	3.5 mm	White or Black	J3
	Not Used	Not Used		C30, C31, C32,C33, X6, JM, JP1

Many of the parts have are sensitive to their orientation (direction) they are soldered in the board. Double check the electrolytic caps before soldering them in, you will release the magic smoke if you power the board up with these in wrong. Normally the + side has a longer lead, and the - side is well marked.

Take care with the trimmer cap orientation. Normally we do not think of these as polarity sensitive, but in a way they are. The side that is connected to the adjustment hole goes to ground. So your screwdriver used for adjustment will not cause capacitance change. If you put it in backwards it will still work but you may find it difficult to adjust.

There is one torrid to wind. There are a number of other inductors in the circuit, but in those cases I simply used fixed inductors of standard values so that you did not have to wind them. T1 is on a FT50-43 core (included in your kit) The secondary is wound first and is 23 turns of any smallish magnet wire. Anything from gauge 24 to 32 would work fine, it's not terribly critical. The primary is 3 turns of insulated hookup wire. I generally find that Ethernet cable makes a good source of hookup wire. It's seems to be relatively inexpensive, and available everywhere. Strip it, and cut off what you need. Lots of different colors to pick from. This transformer matches your 50 ohm antenna with the 3000 ohm input impedance of the first mixer. If you happen to have a 75 ohm antenna, then you can reduce the number of turns on the primary to 19 turns for a better match.

When you are installing J1, the RCA jack, you may find it to be a tight fit. The plastic nibs on the bottom will hang over the edge of the board and you may have to bend the center pin in towards the other pin to get it to fit.

If a power connector is included in your kit, you will have to break off the side pin. Just bend it up and it should break off easily. If you don't have a power connector in your kit, just solder your power wires into the holes for J4.

I recommend that you solder everything in, except the SA612 mixers in the board first. Then power the board up with a regulated 12 to 15 volt power source. And check the voltage on pin 8 of both the SA612's If everything was put together properly you should see something close to 7.5 volts there. If that's ok, remove power and solder in the mixer chips, carefully noting the orientation (they face in opposite directions).

You will get 5 crystals in your kit. Four 11059 for the crystal filter, and one 11.046 for the BFO. The 4 filter crystals you receive in your kit are a matched set. So if you order more than one kit don't mix up the crystals. Some of them may have a mounting wire attached to the top, just cut that off. You can attach a ground wire across the tops of the 4 filter crystals and solder it to each crystal, there are ground holes at each end. I didn't bother with that, but it does improve the blow-by in the filter and reduce spurious signals.

OPERATION:

External connections:

You need to connect a VFO. to J2 If you are using my DDS, it is simplest to use a piece of coax, soldered in both ends. If you want to be able to disconnect them then put a connector on one end. The boards are the same size, and if you stack them, you can probably get away with a twisted pair of wires for the VFO signal. If you are using a different VFO, you will need about 250mV peak to peak. You can also use a crystal instead of a VFO signal. (The crystal goes in to X6, ~47pF caps in C32, C33, and a ~50 or 70pF trimmer in C31.)

You need to connect to a 12-15V power source, well regulated, no AC ripple. You don't need more than 100mA, but wall warts normally have too much ripple. If you hear AC hum in the audio output, that's from your power supply. A battery will also work. You can connect this in using the J4 connection. But you can also use the unmarked square pad near C33. If you have a DDS VFO you can use this connection to wire power from the DDS board, and supply your main power to the DDS board.

You will need to connect something to the audio output. Amplified computer speakers work well. Headphone will work on the low band, but not very well on the high band. You can also connect it to your computer 's "line in" input.

If you have the 2 band kit, you should connect a twisted pair from the pads marked "band" (next to the Antenna input) to PIN5 of J3 on the DDS board. On the GCRX board, the square pad closer to C30 is the ground, the other square pad is the signal. You can also connect this signal to a band switch instead. A high (3 to 10 volts) will select the low band, a low or open circuit will select the high band.

You also need an outside antenna. I use a simple long wire 50 feet long, about 15 feet high, with a tuner to match it to approx 50 ohms. The tuner is not important 7 Mhz and below. But on the higher frequencies, I don't hear much unless the antenna is tuned. For test purposes, you may be able to hear your local AM broadcast stations, with just a short wire in the shack. But keep in mind that computers, and most modern electronics emit a wide range of frequencies that you will also pick up.

There are separate ground planes for the input section, and the rest of the board. In most cases you will want these connected together, and there is a narrow trace connecting them together on the top side of the PCB under the white text "N3ZI GCRX" You can cut this trace if you want separate grounds, and you can reconnect the two ground planes with a jumper at JP1. It depends on your antenna and shack grounding. In most cases just stick with the default.

Calibration:

It is important to set the BFO. Set it to the low side of the crystal filter. Generally the crystal filter will have a passband from approx 11053.5 to 11056.5. In most cases the BFO should be set to 11053.25 but the exact setting will depend on the exact frequencies of the filter crystals.

If you have no test equipment, use the following procedure. Set the DDS VFO to a IF of -11053.25, set the operating frequency to the strong AM broadcast signal, WWV on 5.0 or 10.0 MHz is good if you can receive that, but also any of your local AM broadcast stations will work. Adjust the BFO trimmer cap to zero beat the carrier. If you have another receiver, you can simply listen for the BFO signal, and adjust it to be 11053.25

However, this setting will only give you a starting point. You will need to fine tune the BFO. You can also use a PSK31 software to help you observe the frequency spectrum being put out. Digipan and most others have a nice waterfall display that will essentially give you a display of the spectrum. You want the spectrum to be from approx 300Hz to 3KHz. There is some degree of personal preference in the exact setting.

Once the BFO trimmer is tweaked in, you have to change the IF setting in the DDS to match. If you have another receiver with an accurate digital readout, then you can use that to measure the BFO frequency. If not, then use this method: Tune to a strong AM reference station, either WWV on 5 or 10MHz, or an AM broadcast station. Zero beat the carrier this time using the rotary encoder on the DDS. Then note the DDS digital display reading. Calculate how far off the reading is vs/ the expected frequency. i.e. If you zero beat WWV at 10,000.5 then you know you are 0.5KHz high. Now increase the IF setting by exactly that amount. You will have to make this change to the IF setting in all the memories, because each memory can store a different IF. The IF should be negative for operating frequencies below 12 MHz, and should be the same value, but positive for frequencies above 12 MHz.

If you have strong AM broadcast signals in your area, they may overload the receiver. Sometimes you will hear them at unusual frequencies, sometimes you will hear mixed products from them. The easiest thing to do is to build a simple filter to knock them out. Put two 1000pF caps in series, and a 1 or 1.5 uH inductor at the center point to ground. Put this in series with your antenna. This will roll off the low frequency response below 3 MHz. If you have just one strong station that is bothersome, you can design a notch filter just for the one frequency.

Normally you use a negative IF value for reception below 11MHz, and a positive value for above. This gives you LSB for the lower frequencies, and USB for the higher ones, which is the norm. There are some exceptions. 60M is one, here USB is directed by

FCC rules. To receive on 60M you will need to set the IF to a positive number. I suggest you set up a special memory for this. If you are using the serial port to set frequencies, you can leave the IF the way it normally is, negative, but just enter the frequencies as negative numbers. Occasionally this is useful for shortwave listening. AM signals have both sidebands. Both are the same. Normally, below 11MHz, with a negative IF setting, you will be listening to the LSB. If you enter the operating frequency as a negative number you will get the opposite sideband. If there is interference on one side of the signal you might find this useful.

Other Versions: This manual is for the most popular 2 band version of the receiver. Other version of this kit do not have separate manuals. With your kit you will receive a packing list (BOM) that will indicate the parts and location designators for those parts. Some of the parts will have different values, and some parts may not be included. Follow those instructions. Most of these versions do not include the relay, so the relay must be jumpered to select the supplied filter included with your kit. If your kit does not include the 2nd IF amplifier (Q2), you will need to jumper from the base to collector of Q2. Schematics & photos are available on line.

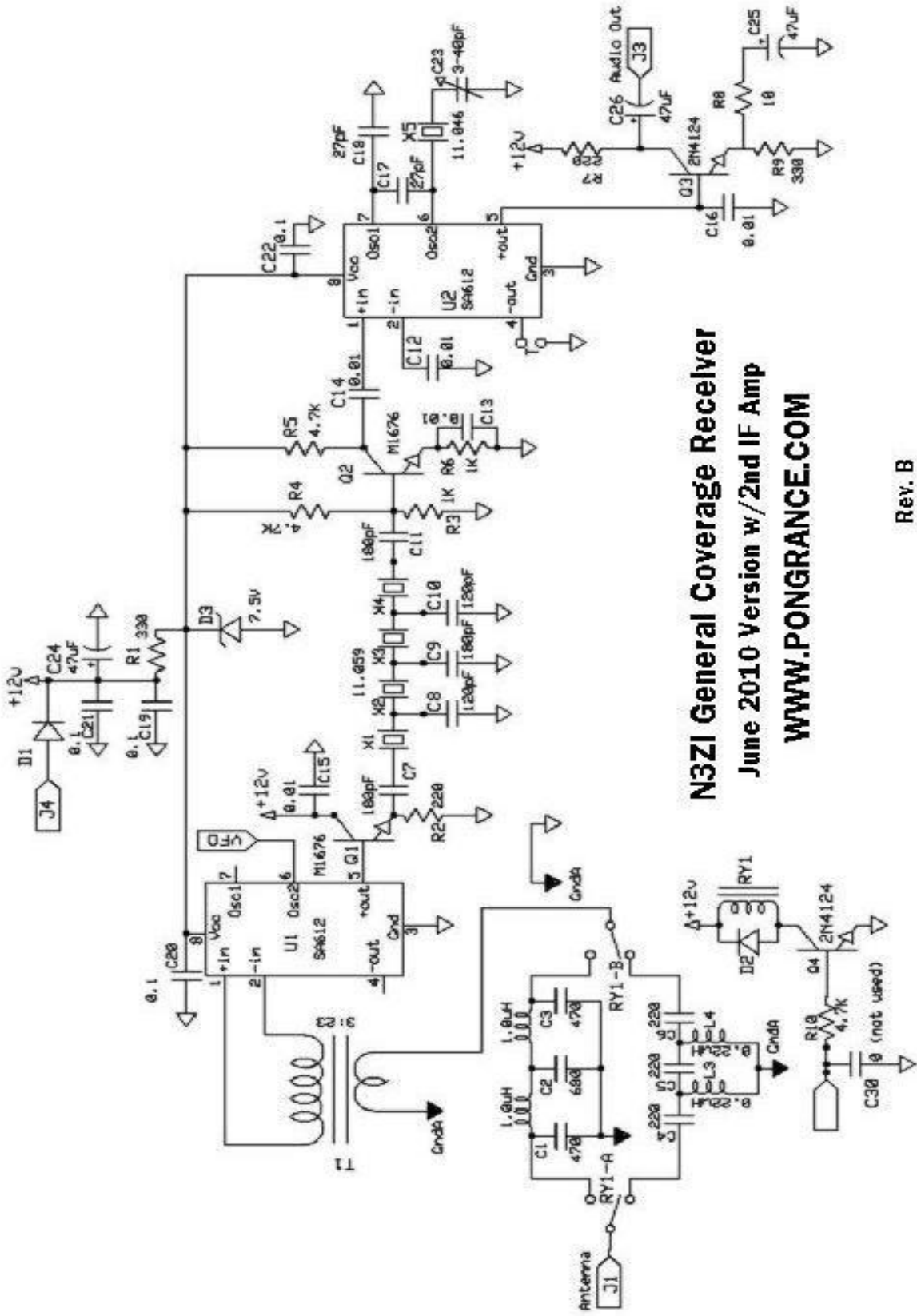

N3ZI General Coverage Receiver
June 2010 Version w/2nd IF Amp
WWW.PONGRANCE.COM